

4

3

2

1

NOTICE
 THIS DRAWING CONTAINS A PROPRIETARY DESIGN ASSIGNED TO SPIRA INTERNATIONAL, INC. ALL RIGHTS TO DUPLICATE, TRANSFER OR USE ARE EXPRESSLY RESERVED BY SPIRA INTERNATIONAL. THE BUYER IS LICENSED TO BUILD ONE ASSEMBLY FROM THESE PLANS.

REVISIONS				
ZONE	LTR	DESCRIPTION	DATE	APPROVED
	A	CORRECTED SPECIFICATION TABLE	03/04/21	JJS

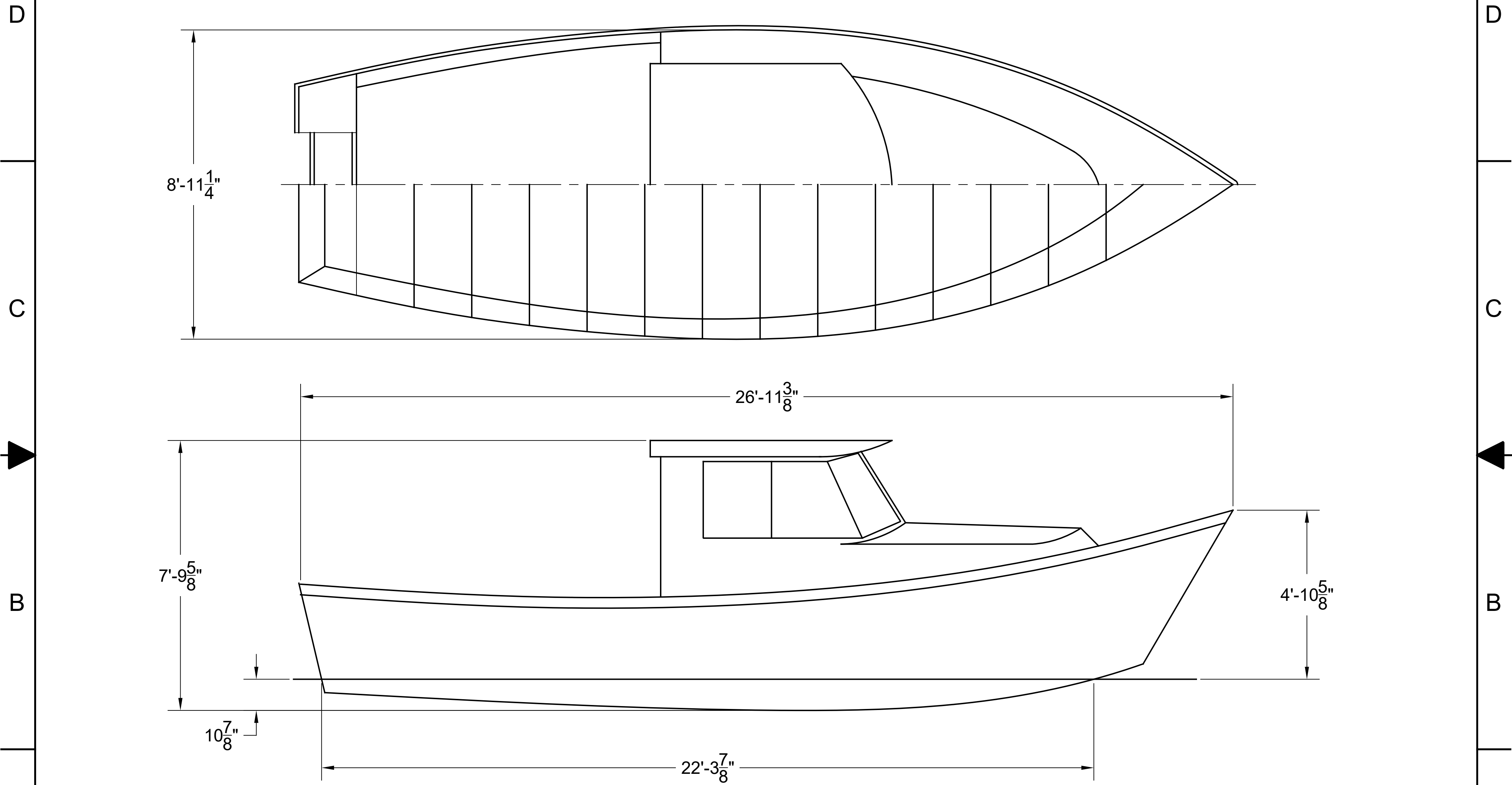

SPECIFICATIONS	
MAX. DISPLACEMENT	9100 LBS
HULL WEIGHT	2700 LBS
CALC. MAX. HORSEPOWER	200 HP
RECOMMENDED HP	90 HP

 **Spira International, Inc.**
 Huntington Beach, California

VALDEZ
 27' POWER DRIFTER

DRAWN BY: J. SPIRA	DATE: 10/25/14	DRAWING NO. VALD01
-----------------------	-------------------	-----------------------

SCALE 1/2" = 1' SHEET OF

4

3

2

1

A

A

B

B

C

C

D

D

4

3

2

1

NOTICE
 THIS DRAWING CONTAINS A PROPRIETARY DESIGN ASSIGNED TO SPIRA INTERNATIONAL, INC. ALL RIGHTS TO DUPLICATE, TRANSFER OR USE ARE EXPRESSLY RESERVED BY SPIRA INTERNATIONAL. THE BUYER IS LICENSED TO BUILD ONE ASSEMBLY FROM THESE PLANS.

REVISIONS				
ZONE	LTR	DESCRIPTION	DATE	APPROVED

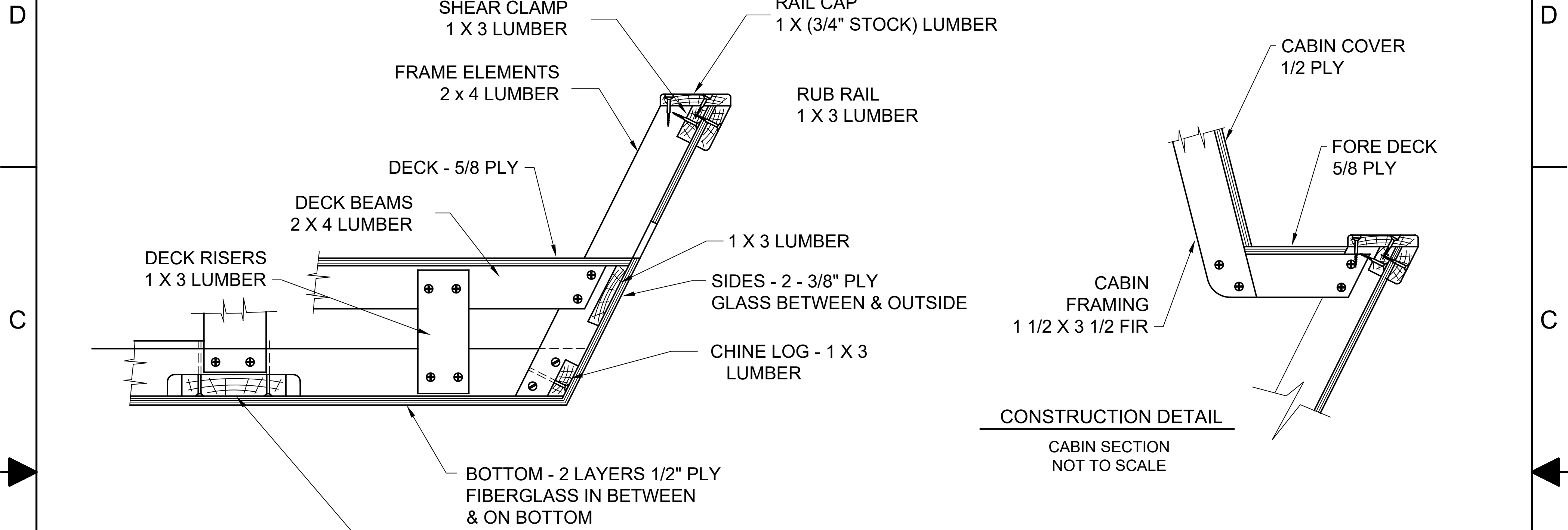

CONSTRUCTION DETAIL
 TYPICAL AT AFT SECTION
 NOT TO SCALE

FASTENING SCHEDULE
 2x FRAME TO 2x FRAME: #10 X 2 -1/2 DECK SCREWS
 LONGITUDINAL TO FRAME: #8 X 2 DECK SCREWS
 PLANKING TO FRAME: #8 X 1-1/2 DECK SCREWS

NOTES:
 1. YOU MAY SCARF TOGETHER SHORTER PIECES TO CREATE THE LONGITUDINAL ELEMENTS.
 2. NOMINAL LUMBER SIZED CALLED OUT, E.G. A 2 X 4 LUMBER IS ACTUAL SIZE 1-1/2" X 3-1/2"

BILL OF MATERIALS (HULL)
 FRAMES: 360 FT 2X4S
 KEELSON & TRANSOM: 32 FT 2X8S
 S/C & C/L: 210' 1X3S
 SIDES: 14 SHTS 3/8" PLY
 BOTTOM: 12 SHTS 1/2" PLY
 GLASS: 75 YDS - 6 OR 10 OZ CLOTH
 EPOXY: 8 GAL
 FRAMES: 150 - #10 X 3" SCREWS
 200 - #8 X 2" SCREWS
 PLANKING: 2500 - #8 X 1-1/2" SCREWS
 DECKING: 6 SHTS 5/8 PLY
 RAIL CAP: 60' 1X8

BILL OF MATERIALS (CABIN)
 FRAMES: 64 FT 1X4S
 48 FT 1X8S
 SIDES: 6 SHTS 1/2" PLY
 GLASS: 12 YDS - 6 OZ CLOTH
 EPOXY: 2 GAL
 SCREWS: 200 - #8 X 1-1/2" SCREWS

CONSTRUCTION DETAIL
 CABIN SECTION
 NOT TO SCALE

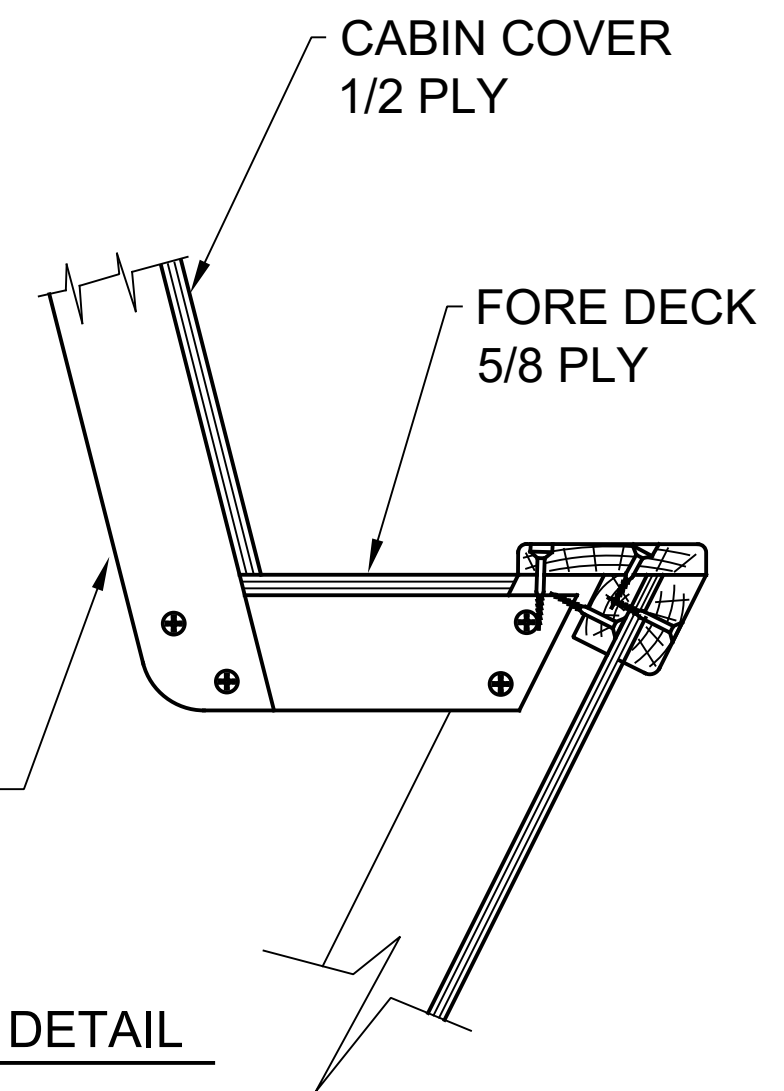

 **Spira International, Inc.**
 Huntington Beach, California

VALDEZ
 27' POWER DRIFTER

DRAWN BY: J. SPIRA	DATE: 10/25/14	DRAWING NO. VALD02
SCALE 1/2" = 1'		SHEET OF

4

3

2

1