

4

3

2

1

**NOTICE**  
 THIS DRAWING CONTAINS A PROPRIETARY DESIGN ASSIGNED TO SPIRA INTERNATIONAL, INC. ALL RIGHTS TO DUPLICATE, TRANSFER OR USE ARE EXPRESSLY RESERVED BY SPIRA INTERNATIONAL. THE BUYER IS LICENSED TO BUILD ONE ASSEMBLY FROM THESE PLANS.

REVISIONS				
ZONE	LTR	DESCRIPTION	DATE	APPROVED
	B	ADDED SPEC SHEET	04/13/19	JJS

D

D

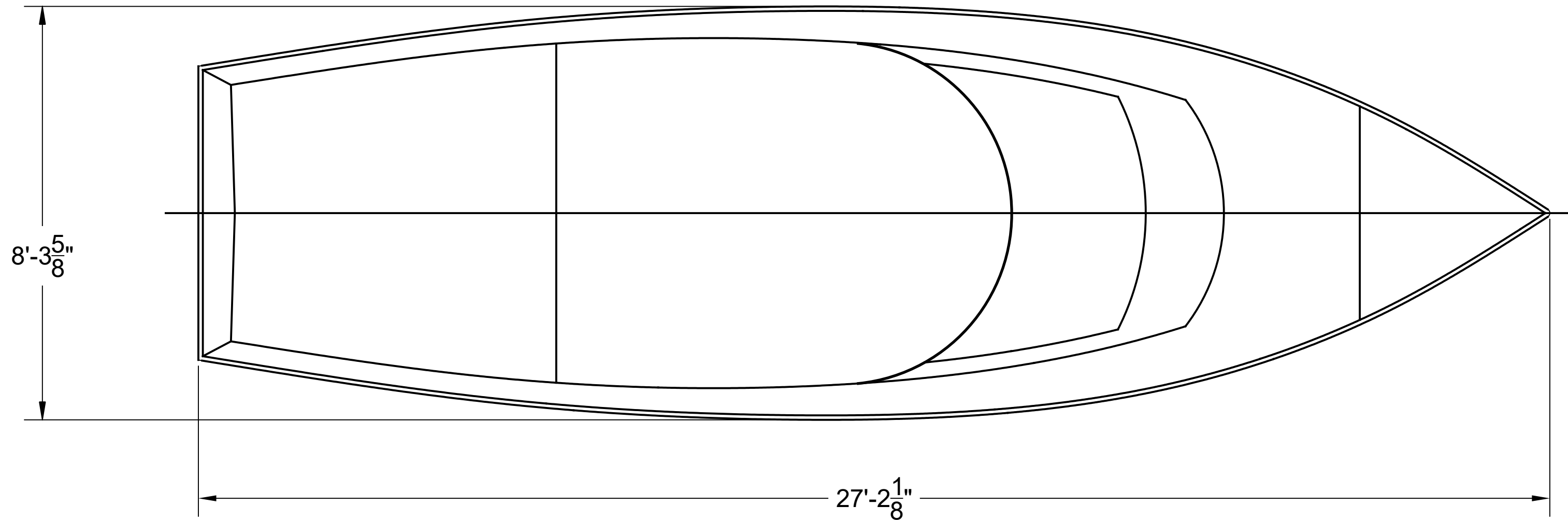

C

C

B

B

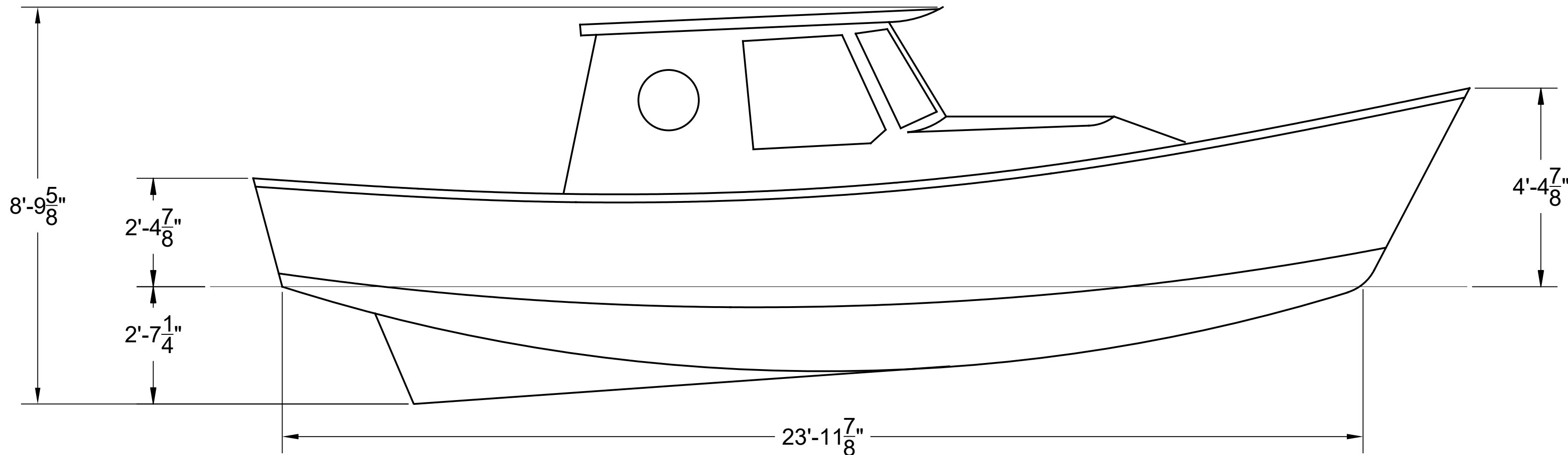

B

B

A

A

SPECIFICATIONS	
MAX. DISPLACEMENT	16200 LBS
HULL WEIGHT	2150 LBS
RECOMMENDED HP - INB'D	35 HP
RECOMMENDED HP - O/B	50 HP

 **Spira International, Inc.**  
 Huntington Beach, California

**SAN MIGUEL**  
 27' DISPLACEMENT CRUISER

DRAWN BY: J. SPIRA	DATE: 02/02/08	DRAWING NO. SANM01
-----------------------	-------------------	-----------------------

SCALE 1/2" = 1' & NOTED SHEET OF

4

3

2

1

4

3

2

1

**NOTICE**  
 THIS DRAWING CONTAINS A PROPRIETARY DESIGN ASSIGNED TO SPIRA INTERNATIONAL, INC. ALL RIGHTS TO DUPLICATE, TRANSFER OR USE ARE EXPRESSLY RESERVED BY SPIRA INTERNATIONAL. THE BUYER IS LICENSED TO BUILD ONE ASSEMBLY FROM THESE PLANS.

REVISIONS				
ZONE	LTR	DESCRIPTION	DATE	APPROVED
	A	ADDED BOM	04/03/12	JJS

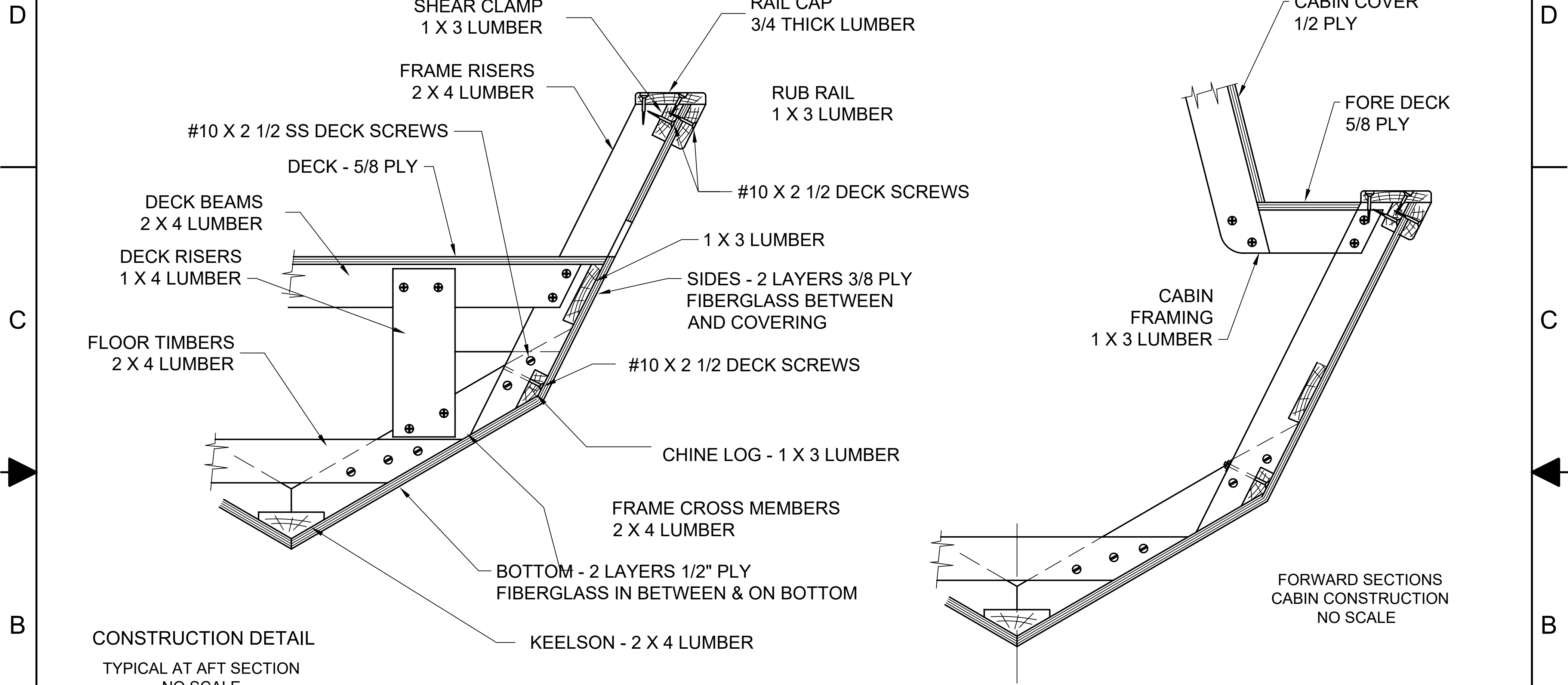

**CONSTRUCTION DETAIL**  
 TYPICAL AT AFT SECTION  
 NO SCALE

**BILL OF MATERIALS**

- 10 SHEETS 3/8" PLY
- 10 SHEETS 1/2" PLY
- 6 SHEETS 5/8" PLY
- 240' 2X4 LUMBER FOR FRAMES
- 280' 1X3 CLEAR LUMBER FOR SHEER CLAMP, CHINE LOG AND RUB RAILS
- 32' 1X4 LUMBER FOR DECK RISERS
- 500 #10 X 2 1/2 SS OR BRONZE DECK SCREWS
- 2000 #8 X 2 SS DECK SCREWS OR BRONZE NAILS
- 15 GAL EPOXY RESIN
- 100 YDS 6 OZ FIBERGLASS CLOTH

**NOTES:**

1. YOU MAY SCARF TOGETHER SHORTER PIECES TO CREATE THE LONGITUDINAL ELEMENTS.
2. NOMINAL LUMBER SIZED CALLED OUT, E.G. A 2 X 4 LUMBER IS ACTUAL SIZE 1-1/2" X 3-1/2"



**SAN MIGUEL**  
 27' DISPLACEMENT CRUISER

DRAWN BY: J. SPIRA	DATE: 02/02/08	DRAWING NO. SANM02
SCALE 1/2" = 1' & NOTED		SHEET OF

4

3

2

1